

ACA Fiber Optic Accessories Training

Optical Ground Wire Accessories

- Bolted Dead Ends
- Suspensions
- Tangent Supports
- Clamps
- Comealongs
- Vibration Dampers
- Connector Kits
- Enclosures
- Bonding Wire Assembly

ADSS Accessories

- Dead End
- Formed Wire Suspensions
- Trunions/Mini Bracket
- Clamps
- Temporary Grips
- Spiral Vibration Dampers
- Connector Kits
- Enclosure

Dead End Assemblies

OPT-GW Bolted Dead End

- A full tension termination unit with breakaway head BOLTS used to apply a precise gripping force to hold the cable without affecting optical fiber performance.

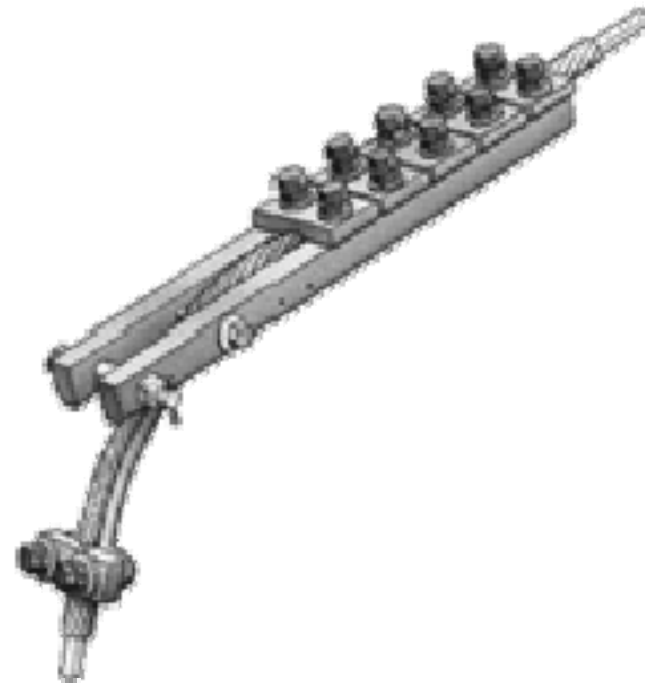

OPT-GW Bolted Dead End Features

- Cable Guide recommended to train OPT-GW down or around the structure.
- Drilled and tapped for grounding lug, eliminating additional accessories for electrical bonding.
- Shorter than formed wire dead ends, allowing installation from the support structure.
- Faster installation than competitive designs which reduces installation cost.
- Optional link plate for extension from structures.

OPT-GW Bolted Dead End Specifics

- Due to aluminum/alloy combos, testing is required to ensure hold strength without compromised optics
 - Specs required to determine number of keepers and groove dimensions.
- OAD – High fiber and S1 OPT-GW cable, includes bushed keeper
- ODE – All other OPT-GW designs

ADSS Wedge Dead End Assembly

- A full tension termination unit with WEDGE design used to apply a precise gripping force to hold the cable without affecting optical fiber performance.



ADSS Wedge Dead End Features

- Designed for ease of installation- four step process with no special tools.
- Wedge design is safer than spiral wrap styles.
- Two lengths for double jacket ADSS cables – 10" and 16".
- Hold strength 100% of MRCL.
- Double Jacket load ratings –
 - 10" wedge = 1500 lbs
 - 16" wedge = 2400 lbs
- Available for cable diameter between 0.512" to 0.984".

ADSS Wedge Dead End Changes

- Manufacturing changes have been made to reduce costs of 16" product.
- Both 10" and 16" wedges are now serrated.
- New Item Number Example –
ADEW16J2-AL535

ADSS Wedge Dead End Naming

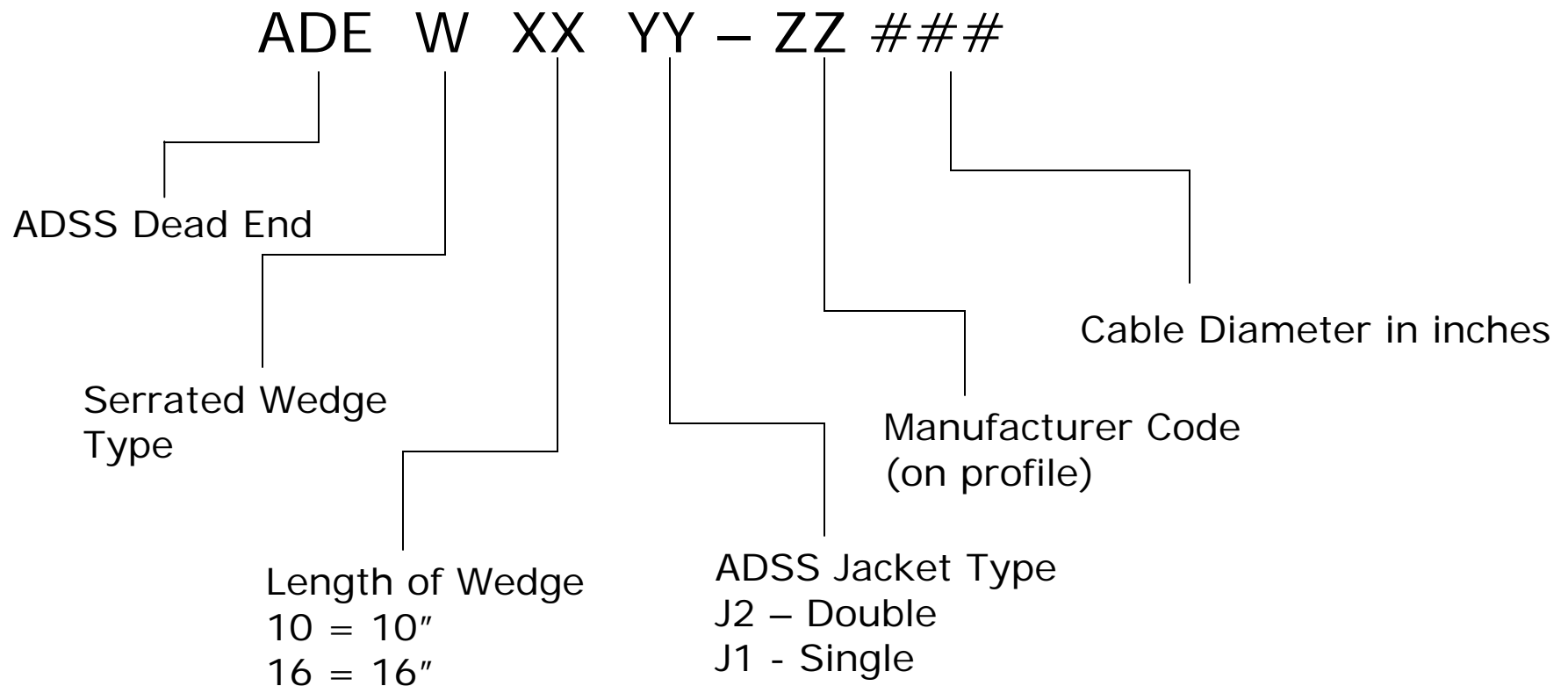

ADSS Wedge Dead End Availability

- Limited tooling availability for serrated wedge groove:
 - 0.512"
 - 0.535"
 - 0.559"
 - 0.575"
 - 0.610"
 - 0.626"
 - 0.858"
 - 0.964"
- Testing required for cable diameters outside of list

Mini-Span[®] ADSS Dead End

- Manufactured outside of ACA
- Typically only sold for Mini-Span .484" diameter ADSS cable
- **ADEMS484** item number

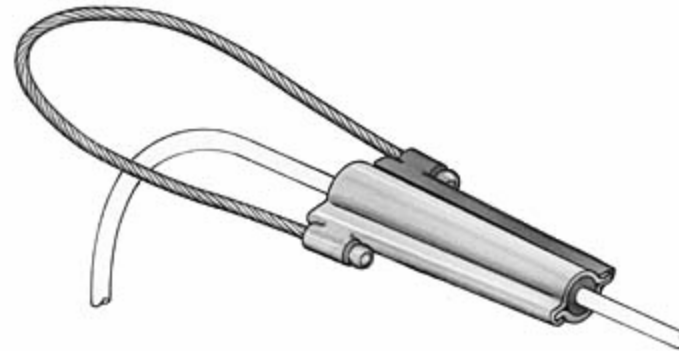

Formed Wire Dead Ends

- A full tension termination unit with FORMED WIRE design used to apply a precise gripping force to hold the cable without affecting optical fiber performance.



Current ADSS Formed Wire Dead End Naming

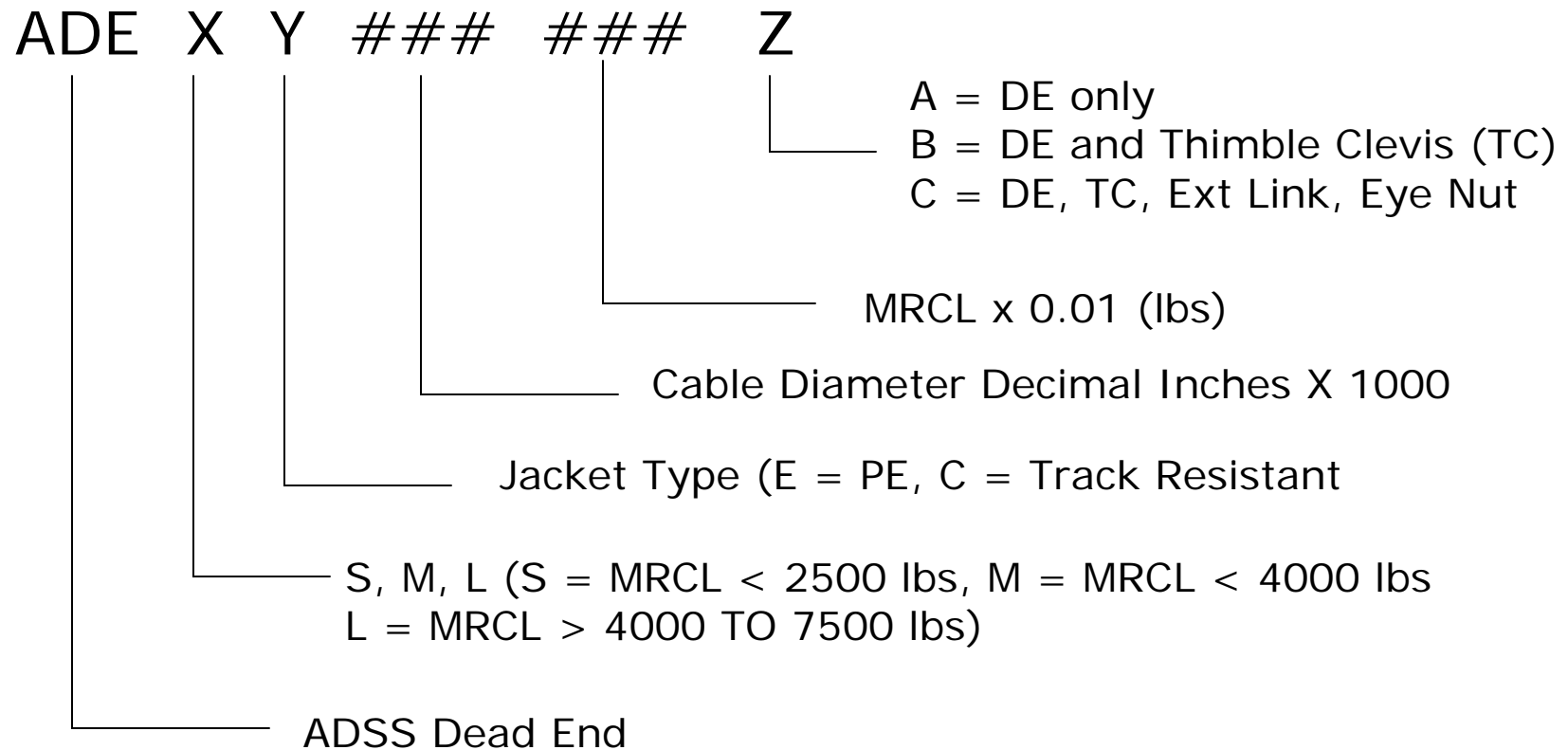

Suspensions

OPT-GW Mechanical Suspension

- Mechanical Suspension supports spans of OPT-GW cable through line angle changes up to 30 degrees. The unique design allows the compact unit to support vertical cable loads and unbalanced cable loads without damaging the cable strands or affecting optical fiber performance. Shoe and armor rods supplied as set.

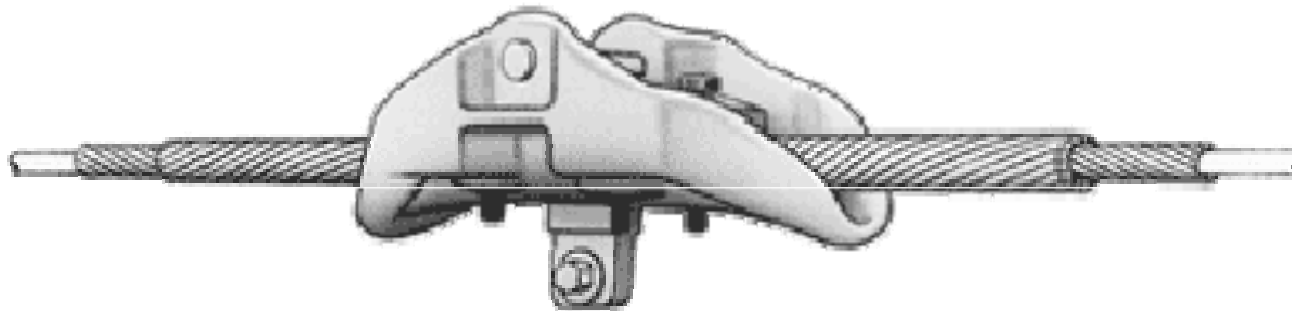

OPT-GW Mechanical Suspension

- Slip strengths: > 3,000 lbs (depending on cable design)
- Vertical load rating: 15,000 lbs
- Meets IEEE 1138 Vibration and Galloping tests
- Compact design: Only 34” in length
- Break-away bolts ensure proper installation torque while eliminating the need for specialized torque wrenches
- Double Suspension used on angles >31 degrees
- Lighter weight; easier installation
- Ideal for helicopter installation
- Unique keeper design allows installation without removing bolts; fewer loose parts
- Drilled and tapped for grounding lug; eliminates additional accessories for electrical bonding
- Shorter than formed wire suspensions; allows installation from the support structure

OPT-GW Mechanical Suspension

- Item numbers are range-taking
 - Example
 - Single Suspension – **SUME528/555**
 - Double Suspension – **ODSME528/555**
 - No naming changes
- Cable diameters covered
 - 0.421" – 0.730"
- Clevis Eye and Link Plate attachment hardware sold separately

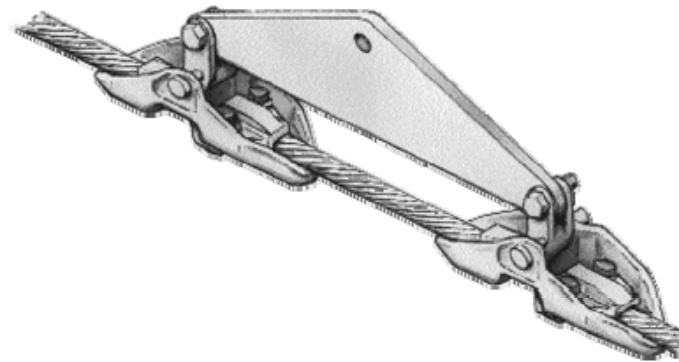
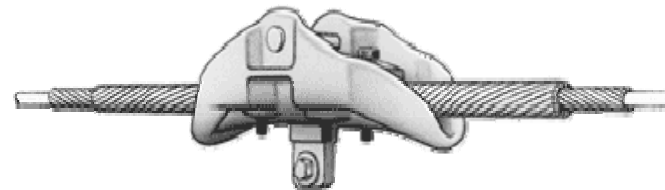

ADSS Formed Wire Suspension



- Naming is range-taking – **ASUXXX/YYY** – no changes.
- Vertical load rating: 15,000 lbs.
- Maximum line angle for single suspension is 30°.
- Double Suspension also available for 60” line angles.
- Attachment hardware sold separately.

Tangent Supports

ADSS Tangent Support (Trunion)

- Trunion used as cable support on tangent structures within a line or stringing unit (without bushing).
- Maximum line angle for permanent installation 22°.
- Rated up to 600 ft. NESC Heavy conditions.
- No loose parts.
- **NOT TO BE USED ON TRACK RESISTANT CABLE.**



ADSS Tangent Support

- Naming is range-taking – no changes
 - Example – **ATGN475/525**
- Cable diameters covered:
 - 0.424" to 1.045"
- Banding slot option is standard for concrete and steel pole mounting. Banding supplied by customer.

ADSS Mini Bracket

- Mini Brackets are used for short and medium spans of ADSS cable and drop cables.
- Rated Strength is 3000 lbs.
- The bolted supports are supplied with aluminum captive bolts to simplify installation with no loose parts.
- Attachment hardware supplied by customer.

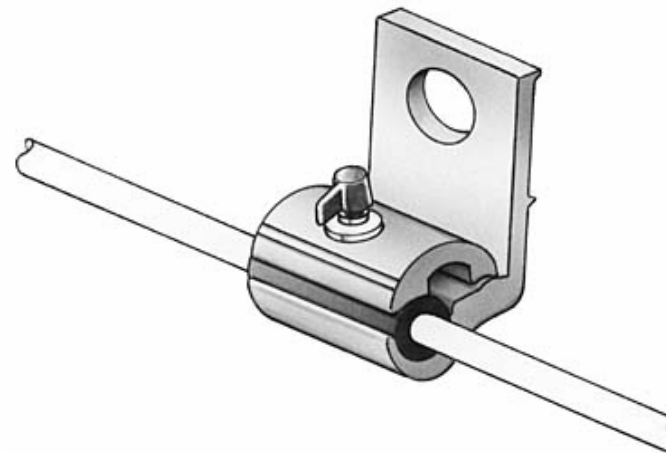

ADSS Mini Bracket Naming

- Existing products are named diameter specific.
- AMBBxxx (xxx cable diameter in inches)
 - **AMBB256**
 - **AMBB307**
 - **AMBB424**
 - **AMBB484-535**
 - **AMBB610**

Bonding and Guide Clamps

OPT-GW Clamps

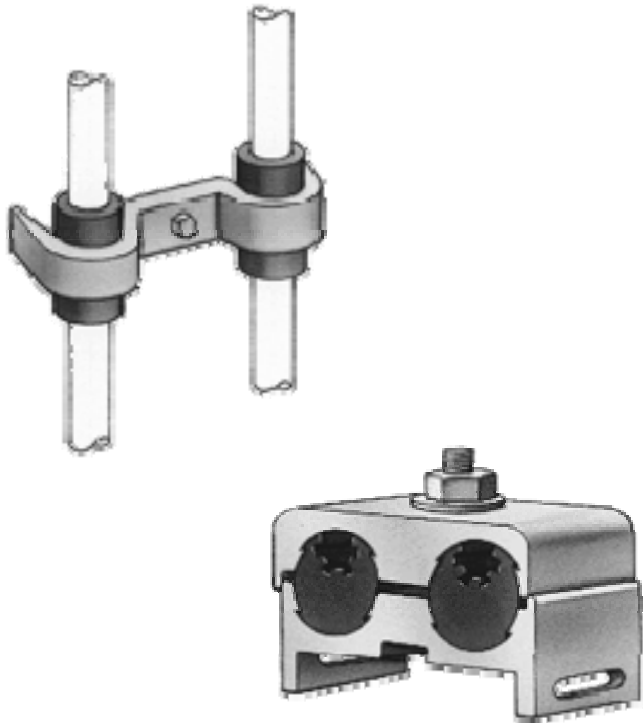

- Provides proper spacing and hold strength without damage to the cable.
- Slip strength: >100 lbs.
- Lattice adapters are provided with break-away bolts for precise torque during installation.
- Steel tower guide clamps available with adapters to eliminate the need for drilling.
- Banding adapters available.
- Corrosion resistant - Long life.
- Easy installation

OPT-GW Bonding Clamp

- Two-groove clamp used to bond OPT-GW to the tower or to the tower grounding wire.
- Alternative to bonding wire assembly.
- **OBCXXX/YYY#**
 - XXX – Run diameter in inches
 - YYY – Tap diameter in inches
 - # - number of bolts (1 or 2 bolts)
- Grooves are coated and prefilled for better conductance.
- No adapter provided/needed, does not attach to structure.

OPT-GW Guide Clamps

- Two-groove clamp used to guide OPT-GW down steel towers, steel, concrete or wood poles.
- Typically spaced 5 to 8 feet apart to maintain alignment down the structure.
- Requires an adapter to attach to structure.
- Four design options:
 - Both grooves same size
 - Grooves different size
 - Downlead clamp with rubber bushings
 - OPT-GW with ADSS downlead clamp

Guide Clamp Naming

- OPT-GW Guide clamp with both grooves same diameter
 - **OGCXXX/YYYYZ**
 - XXX/YYYY – Cable diameter range in inches
 - Z – adapter style (see below)
- OPT-GW Guide clamp with grooves different size
 - **OGCXXX-YYYYZ**
 - XXX – run diameter in inches
 - YYY - tap diameter in inches
 - Z – Adapter style(see below)
- 'Z' at the end of the Guide clamp item number is VERY important; it is how the customer will attach the product to the structure.
 - 'A' – Banding Adapter
 - 'B' – Lattice Tower 0.25" to 0.72" dimension
 - 'C' - Lattice Tower 0.72" to 1.25" dimension

Downlead Clamps

- OPT-GW Downlead clamp with both grooves same diameter
 - ODCXXX/YYYYZ
 - XXX/YYYY – Cable diameter range in inches
 - Z – adapter style
- 'Z' is how the customer will attach the product to the structure.
 - 'A' – Banding Adapter is in lower half of clamp (see picture)
 - 'B' – Lattice Tower 0.25" to 0.72"
 - 'C' - Lattice Tower 0.72" to 1.25"

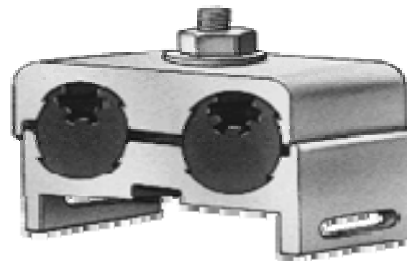

ADSS Guide Clamp for Wood Pole Application

- **OGWXXX/YYY**
 - W is for 'wood'
 - XXX/YYY is range-taking diameter in inches
 - Cable diameter covered
 - 0.469" to 0.750"
- Lag bolt supplied

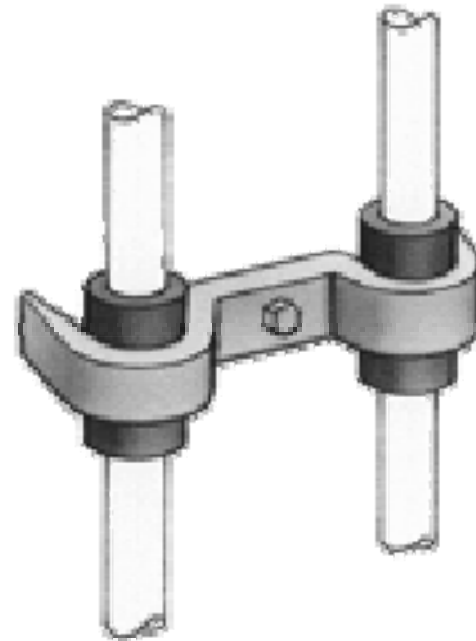

ADSS Guide Clamp for Wood Pole Application

- **AGWXXX/YYYY**
 - W is for 'wood'
 - XXX/YYYY is range-taking diameter in inches
 - Cable diameter covered
 - 0.182" to 0.750"
- Lag bolt supplied

Comealongs and Temporary Grips

Comealongs

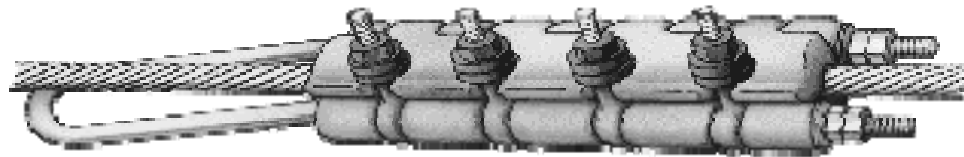

- A temporary grip used during installation, “dead ending,” and “clipping in” of the OPT-GW.
- Sometimes referred to as a “Pocketbook Grip” or “Butterfly Grip,”
- Custom designed for OPT-GW.
- Reusable with proper maintenance.
- 100% factory tested to ensure proper performance on OPT-GW.
- Self-contained unit ALL-IN-ONE, no loose parts.
- Easy installation and removal.
- Compact size.

Comealong Developments

- Extruded frame - NEW
- Current naming is **OCAXXXYYY** – where X indicate cable designation and Y is diameter in inches.
 - Working to make OPT-GW comealongs range-taking for better turnaround on item numbers
 - Future naming will be **OCAXXX/YYY**, where XXX/YYY is a range - 2004

ADSS Temporary Grip

- Used in stringing ADSS during sagging.
- Mechanical grip for polyethylene jackets only.
- Similar design to the Wedge Dead End except with a vice screw design to remove wedges after cable is in place.
- Designed to hold 2500 lbs of load or 50% of MRCL.
- Requires testing to ensure design does not damage cable.
 - **ATGMEMXXXA** – where XXX indicates cable diameter
 - **ATGWXXX** – wedges can be purchased separately; side plates are reusable.

Vibration Accessories

Vibration Accessories

- Stockbridge Dampers
 - OPT-GW only
 - **OVDXXX/YYY** – cable diameter range
- Spiral Vibration Dampers
 - ADSS only
 - **AVDXXX/YYY** – cable diameter range

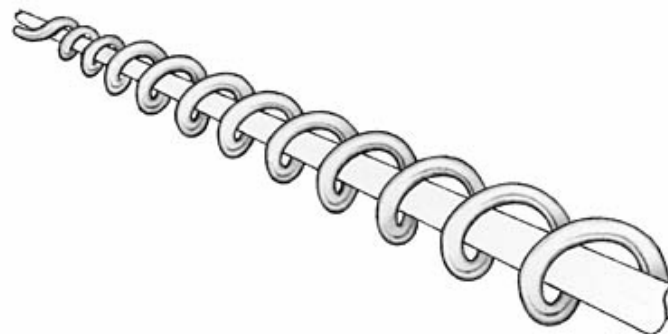

Connector Kits

Connector Kits

- Splice Box connections for OPT-GW, ADSS, and Loose Tube cables.
- Design is VERY dependent on the cable design, therefore SPECS ARE REQUIRED.
- OPT-GW requires a cutting back of the outer strands to get to the fiber holding unit(s).
- ADSS/LT does not require knowledge of internal dimensions except for the diameter of the central strength member (FRP or CSM, where available).
 - Could cause fiber damage if not anchored.
- Flex conduit connectors are available where flexible conduit surrounds outdoor cable to the splice box – indicated with a 'F' at end of item number.
- Supplied with hex nut for SB01 or OG03 installation.

OPT-GW Connectors

- OPT-GW connectors – **OCKXXXYYF**
 - XXX – cross-sectional area of cable
 - YYY – cable diameter
 - F – flex conduit connection (when needed)
- Differs slightly if for competitor cable
 - **OCK###ZZZ**
 - ### - cable diameter in inches
 - ZZZ – Vendor name

ADSS/LT Connector Kits

- ADSS connector kits
 - **ACKXXXYYF**
 - XXX – outside cable diameter in inches.
 - YYY – FPR/CSM diameter in inches, where applicable.
 - F – Flex conduit connection, where applicable.
- Loose Tube (LT) connector kits
 - **LCKXXXYYF** – as above

Opti-Guard Connector Kits

- Opti-Guard enclosure has six ports
 - Four ports are 1" diameter
 - Two ports are 1.25" diameter
- OGK connectors fit the 1.25" port
 - Named similar to OCK connectors
 - **OGKO** - OPT-GW with central tube
 - **OGKA** - ADSS or LT
 - **OGKM** – OPT-GW with multiple steel tubes

Enclosures

SB01 Splice Box

- Encases optical fibers in a protective environment where splicing of the line or drops are required in the system.
- Four 1" ports, 2 in/2 out.
- One tray supplied, maximum eight (8) splice trays (96F); others sold separately-**ST1**.
- Connectors sold separately.

Opti-Guard Splice Enclosure

- Accommodates up to 540 single fusion splices.
- Accepts various splice trays, including mass fusion.
- Craft-friendly design requires no specialized tools to install.
- Maintenance friendly - no re-entry kit required.
- Lightweight with universal structure mounting (bolted or banded).



Opti-Guard Splice Enclosure

- **OG03** – item number
- Typically banded to pole.
- Cable Storage Unit available